

Plano Técnico General

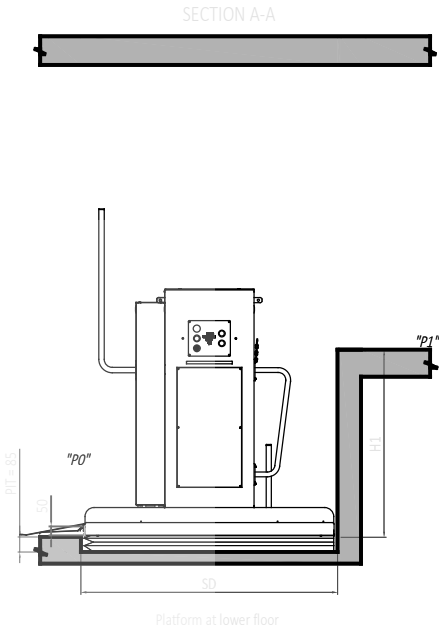
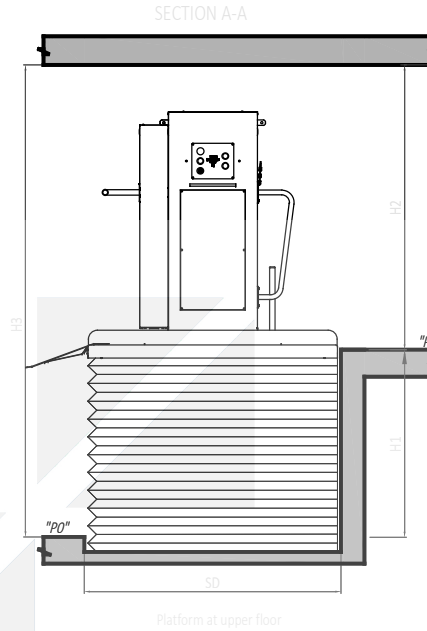
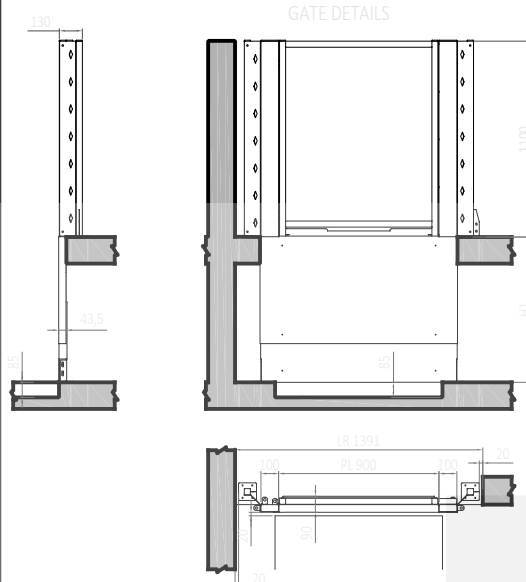
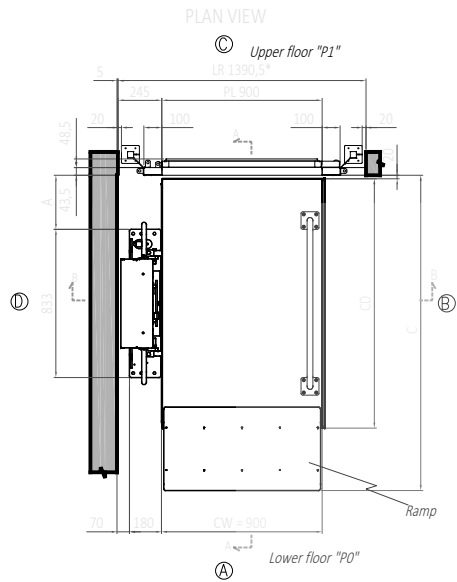

LR = min. width (by the customer)
 LR: Symmetrical version of the platform. (upon request)

Note: gate with opposite opening (upon request)
 Note: compulsory when H1 > 500 mm

ELECTRICAL DETAIL

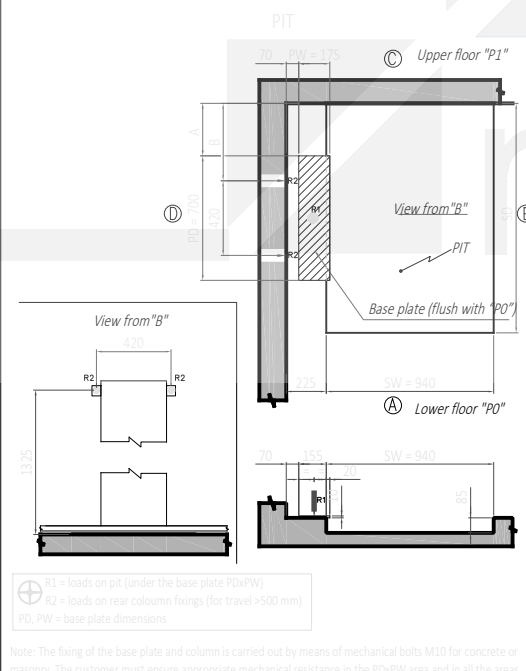
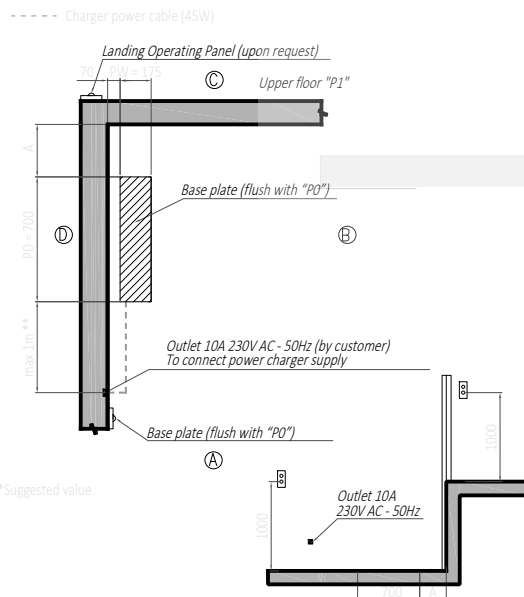

PUMP UNIT FEATURES	
Electrical supply	24V DC - 15A
Capacity	0,88 l/min
Motor Power	500 W
PLATFORM FEATURES	
Electrical supply	230V AC - 0,2 A - 50 Hz
Max Capacity	340 kg
Nominal speed	0,05 m/s

* MIN. VALUE
 ** MAX VALUE

	DIMENSIONS	
	900X1250	900X1400
A [mm]	228	303
B [mm]	435	510
C [mm]	1636	1786
SD [mm]	1290	1440
CD [mm]	1250	1400
A1 [mm]**	1378	1378
A2 [mm]**	1881	1881
B1 [mm]**	70	70
B2 [mm]**	200	200
H1 [mm]**	1000	1000
H2 [mm]*	1600	1600
H3 [mm]**	2400	2400
R1 [daN]	510	540
R2 [daN]	165	175